

B 53040

Vargal® self-locking nuts

Clamping part with spring made of phosphated spring steel

Steel 8 | zinc-plated | Cr(VI)-free | Metric thread

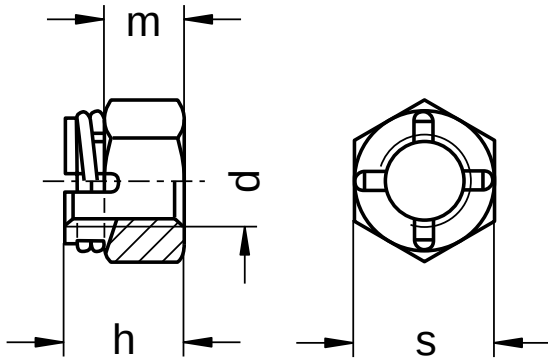

Diameter (d)	h max.	m nominal size	s nominal size	Pitch (P)	Tool size
M5	6.3	4.0	8	0.80	SW 8
M8	10.8	6.7	13	1.25	SW 13
M10	12.6	8.0	17	1.50	SW 17
M12	16.0	10.6	19	1.75	SW 19
M16	20.6	13.5	24	2.00	SW 24
M20	25.5	16.9	30	2.50	SW 30
M24	29.9	20.6	36	3.00	SW 36
M30	37.0	26.6	46	3.50	SW 46

All technical data refer to the measure mm

